

# DURASHEET™

EAVES AND SOFFIT LININGS



Build it better with **BGC**

**BGC**

Fibre Cement

## HISTORY & MISSION

BGC FIBRE CEMENT AND PLASTERBOARD IS A PROUD AUSTRALIAN OWNED MANUFACTURER OF FIBRE CEMENT AND PLASTERBOARD PRODUCTS.



BGC has state-of-the-art manufacturing facilities in Perth and distribution centres in all states of Australia and in New Zealand.

Our distribution network ensures that our entire product range is readily available in all states of Australia and in New Zealand.

BGC has a team of technical specialists that can assist with all specification and design information to help ensure that you always **'build it better with BGC'**.

### BGC HAS INTERESTS IN

- / Residential and commercial building
- / Building and construction products
- / Contract mining
- / Civil engineering construction and maintenance
- / Quarrying
- / Road transport
- / Property ownership and management
- / Insurance

Our mission at BGC is simple – we want to ensure that people can always **'build it better with BGC'**.

In keeping with our mission, we are constantly assessing and improving our products to ensure that we always provide cost effective, high quality and easy-to-use products to the market.



# CONTENTS



5 // PRODUCT DESCRIPTION	
5 // PRODUCT INFORMATION	
5 // QUALITY SYSTEMS	
5 // FIRE RESISTANCE	
5 // SHEET SIZES	
5 // HANDLING & STORAGE	
6 // SHEET CUTTING & DRILLING	9 // EXTERIOR CLADDING
6 // THERMAL BREAKS	10 // SHEET JOINTS
6-7 // FASTENERS	11-12 // BRACING
7 // FIXING REQUIREMENTS	13 // BUSHFIRE WALL & EAVES
7 // SOFFIT/EAVES LINING	14 // PAINTING
8 // GARAGE /CARPORT/ ALFRESCO LININGS	14 // MAINTENANCE
	14 // WARRANTY

# DURASHEET™

EAVES AND SOFFIT LININGS



DURASHEET™ PROVIDES FIRST RATE EXTERNAL CLADDING FOR GABLE ENDS, EAVES, SOFFITS, CAR PORTS AND VERANDAH LININGS. IT'S A GENERAL-PURPOSE SHEET YOU CAN USE ON BOTH TIMBER AND STEEL-FRAMED BUILDINGS.

DURASHEET™ COMES IN TWO THICKNESSES TO SUIT BOTH RESIDENTIAL AND LIGHT COMMERCIAL FIBRE CEMENT APPLICATIONS, SIGNIFICANTLY EXTENDING YOUR PROFESSIONAL SPECIFYING CHOICE.

#### **DURASHEET™**

- // 4.5mm thickness: used mainly in timber-framed residential buildings for soffit/eaves linings and cladding features such as gable ends
- // 6mm thickness: recommended for light commercial applications, cyclonic wind zones and steel framed constructions
- // Classified as Type A Category 2 for exterior use

## PRODUCT DESCRIPTION

Durasheet™ is a general-purpose fibre cement sheet for exterior applications. It is recommended for the cladding of gable ends, eaves, carport and verandah linings of timber or steel framed buildings.

Durasheet™ is a smooth flat square edged sheet and is manufactured in nominal thickness of 4.5mm and 6mm.

4.5mm Durasheet™ is generally used in timber framed residential buildings for soffit linings and the cladding of features such as gable ends.

6mm Durasheet™ is recommended for commercial applications, cyclonic wind zones and steel framed construction.

## PRODUCT INFORMATION

Durasheet™ is manufactured from Portland cement, finely ground silica, cellulose fibres and water. It is cured in a high-pressure steam autoclave to create a durable, dimensionally stable product.

Durasheet™ fibre cement sheets are manufactured to conform to the requirements of AS2908.2 Cellulose-Cement Products and are classified as Type A Category 2 sheet for external use.

## QUALITY SYSTEMS

BGC Fibre Cement manufactures Durasheet™ under the rigorous Quality Management System of the International Standard ISO 9001:2008, and is the holder of Licence Agreement number QEC2955/13.

## FIRE RESISTANCE

Durasheet™ has been tested by the CSIRO – Building, Construction and Engineering Division, in accordance to Australian Standard AS1530.3. See report numbers FNE 6966 and FNE 7529.

This report deemed the following Early Fire Hazard Properties

// Ignition Index	0
// Spread of Flame Index	0
// Heat Evolved Index	0
// Smoke Developed Index	0-1

## SHEET TOLERANCES

Durasheet™ complies with the requirements of AS2908.2

## SHEET SIZES AND WEIGHT

THICKNESS (mm)	WEIGHT kg/m <sup>2</sup>	WIDTH (mm)	LENGTH (mm)				
			1800	2100	2400	2700	3000
			4.5	6.6	450		
		600			✓		
		750			✓		
		900	✓		✓	✓	✓
		1200	✓	✓	✓	✓	✓
6	8.8	900			✓		✓
		1200	✓		✓	✓	✓

Weights are based on Equilibrium Moisture Content.

## HANDLING & STORAGE

Durasheet™ must be stacked flat, up off the ground and supported on level equally spaced (max 450mm) gluts.

The sheets must be kept dry, preferably by being stored inside a building. When stored outdoors they must be protected from the weather.

Care should be taken to avoid damage to the ends, edges and surfaces.

Sheets must be dry prior to being fixed, or painted. Sheets must be carried on edge.

## HEALTH & SAFETY

Durasheet™ as manufactured will not release airborne dust, but during drilling, cutting and sanding operations cellulose fibres, silica and calcium silicate dust may be released. Breathing in fine silica dust is hazardous, prolonged exposure (usually over several years) may cause bronchitis, silicosis or cancer.

## AVOID DUST INHALATION

When cutting sheets, use the methods recommended in this literature to minimise dust generation. These precautions are not necessary when stacking, unloading or handling fibre cement products. For further information or a Material Safety Data Sheet contact any BGC Sales Office.



## SHEET CUTTING & DRILLING

Durasheet™ may be cut to size on site. If using power tools for cutting, drilling or sanding they must be fitted with appropriate dust collection devices or alternatively an approved (P1 or P2) dust mask and safety glasses should be worn. It is recommended that work always be carried out in a well-ventilated location.

The most suitable cutting methods are:

### // SCORE AND SNAP

Score the sheet face 4 or 5 times with a 'score and snap' knife. Support the scored edge and snap the sheet upward for a clean break.

### // DURABLADE

180mm diameter. This unique cutting blade is ideal for cutting fibre cement. It can be fitted to a 185mm circular saw. Please ensure safe practices when using.



### // NOTCHING

Notches can be made by cutting the two sides of the notch. Score along the back edge then snap upwards to remove the notch.

### // DRILLING

Use Tugsten Carbide drill bits. Do not use the drill's hammer function. For small round holes, the use of a Tugsten Carbide hole-saw is recommended.

For small rectangular or circular penetrations, drill a series of small holes around the perimeter of the cut out. Tap out the waste piece from the sheet face while supporting the underside of the opening to avoid damage. Clean rough edges with a rasp.

Large rectangular openings are formed by deeply scoring the perimeter of the opening. Next, form a hole in the centre of the opening (refer method above) then saw cut from the hole to the corners of the opening. Snap out the four triangular segments. Clean rough edges with a rasp.

## THERMAL BREAKS

Thermal breaks are required for steel framed buildings, in walls enclosing habitable and or usable spaces. Careful consideration of thermal heat transfer and the position of thermal breaks need to be addressed by the architects, engineers and building designers.

Balustrades, parapets, and other non-enclosing wall elements may not require thermal bridging, except where the possibility of high thermal heat transfer exists through the steel CFS sections to the main structural steel element of the building.

As part of the BGC Fibre Cement range EPDM Foam Gasket is able to act as a thermal break and is required to prevent moisture ingress at sheet joins. EPDM Foam Gasket can also be used as a Thermal Break Tape and provides an R value of R 0.2 in accordance with the Building Code of Australia.

The EPDM Foam Gasket should be placed on all frame contact faces and at noggins and bottom plates.

Thermal breaks are first installed to all vertical frame members (Studs) then applied horizontally to top and bottom tracks as well as any horizontal noggins.

**NOTE: Thermal breaks (BGC EPDM Foam Gasket) is a self adhesive foam gasket/tape. It is installed over the building wrap (sarking).**

Leave a small gap between the vertical gasket to allow any moisture to escape.

## SARKING

In wall cladding applications the installation of a vapour permeable perforated sarking between Durasheet™ and the framing is recommended.

Under windy conditions the building's internal pressure will generally be less than the external air pressure, this will tend to draw water through flashing and seals if sarking is not used.

Use of a reflective sarking will enhance the insulation properties of the cladding system.

## FASTENERS

### TIMBER FRAMING

Durasheet™ is to be fixed to timber using 30 x 2.8mm Galvanised Flat Head Nails. Nails should be driven just flush with the sheet face. Do not overdrive nails.

#### 30 x 2.8mm Galvanised Flat Head Nail



When using nail guns, if variation occurs the gun should be set to under-drive and the nails tapped home using a hammer.

Use No.8 x 20 Galvanised Wafer Head Screws for fixing 4.5mm Durasheet™ eaves and soffit linings to lightweight steel framing. 4.5mm Durasheet™ should not be used for cladding steel framed walls.

No. 8 x 20mm Galvanised Wafer Head Screw

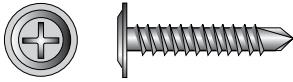

6mm Durasheet™ claddings are fixed to lightweight steel framing using No.8 x 20 Galvanised Self-Embedding Head Screws. Screws should be driven just flush with the sheet face. Do not overdrive screws. Self-Embedding Head Screws must not be used with 4.5mm Durasheet™.

No. 8 x 20mm Galvanised Self Embedding Screw

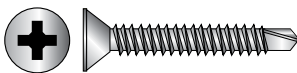

FIXING REQUIREMENTS

Sheets to be fixed along all sheet edges over studs on wall cladding applications. Fixings centres must not exceed 200mm for wall cladding and 300mm for soffit linings.

Do not place fixings closer than 12mm from sheet edges, or closer than 50mm from the sheet corners.

Do not overdrive fasteners.

The sheet must be held firmly against the framing when fixing to ensure breakout does not occur on the back.

Coastal Areas – The durability of galvanised nails and screws used for external cladding in coastal or similar corrosive environments can be as low as 10 years.

For this reason BGC recommends the use of stainless steel or class 4 fasteners within 1km of the coast or other large expanses of salt water.

The sheet edges must be supported either by nailing at 300mm maximum centres or by a construction feature such as a grooved fascia board or along an external brick wall.

The sheets may be joined on framing when PVC joiners are used.

Where sheets are joined off framing, the bearer centres of the span are not to be greater than 450mm for 4.5mm Durasheet™ or 600mm for 6mm Durasheet™.

Where a metal roof is installed directly above soffits, severe thermal movement may occur. Where Durasheet™ is used, it is preferred the roof be vented to allow emission of hot air as well as providing a reduction in roof space temperature.

For General Application

For eaves to 600mm maximum width:  
// Eave bearers must be provided at a maximum of 600mm centres.

For eaves 600mm ~ 1200mm wide:  
// Eave bearers must be at a maximum of 450mm.

Refer to table below for specific wind categories

FIGURE 1 // TYPICAL BOXED EAVES LINING

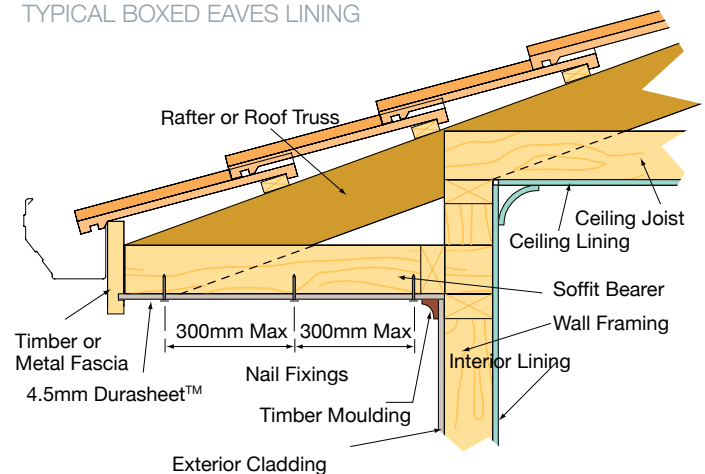

BOXED EAVES // MAXIMUM BEARER AND FASTENER SPACING

SHEET EDGES SUPPORTED ON FRAMING - 4.5MM DURASHEET™

MAXIMUM EAVES WIDTH (MM)	AS4055 WIND CLASSIFICATION	WITHIN 1200MM OF THE EXTERNAL BUILDING CORNERS		ELSEWHERE IN BUILDING	
		TRIMMER SPACING	FASTENER SPACING	TRIMMER SPACING	FASTENER SPACING
TO 600 MAXIMUM	N1	600	300	600	300
	N2	600	300	600	300
	N3/C1	450	250	600	300
	N4/C2	375	200	500	300
> 600 TO 1200 MAXIMUM	N1	600	300	600	300
	N2	550	300	600	300
	N3/C1	450	250	600	300
	N4/C2	375	200	500	300

## GARAGE / CARPORT / ALFRESCO LININGS

Typically, when lining a carport with Durasheet™, sheets are to be installed at right angles to the ceiling joists and/or battens using PVC sheetholders to support all sheet joints.

The ends of the sheets should be staggered with a maximum gap of 5mm to facilitate the PVC sheetholder.

The sheets must be nailed at 300mm maximum centres along each ceiling joist / batten.

The outer sides and ends of perimeter sheets must be supported by framing and nailed at 300mm maximum centres.

**Durasheet™ must not be fixed directly to the bottom chord of roof trusses. Timber battens or metal furrings should be installed.**

**FIGURE 2 //**  
GARAGE / CARPORT / ALFRESCO LININGS

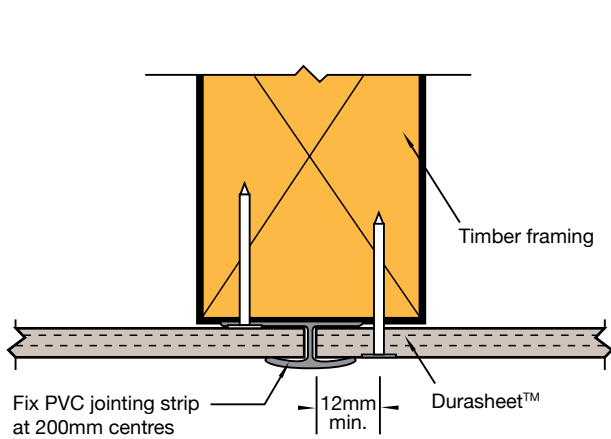

Battens / Ceiling Joists centres  
4.5mm Durasheet™ = 450mm max.  
6mm Durasheet™ = 600mm max.

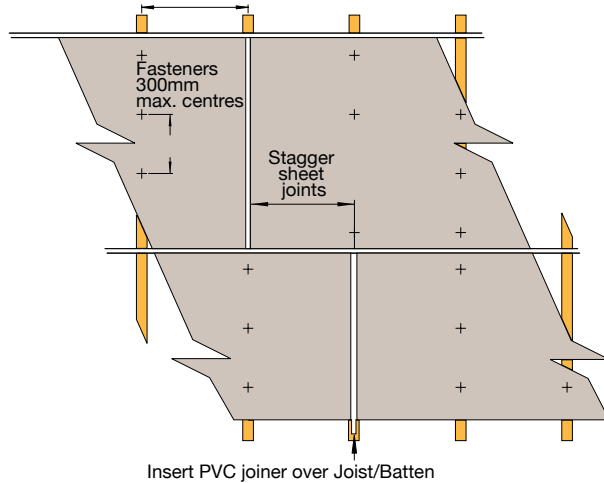

**FIGURE 3 //**  
EXPRESSED JOINT

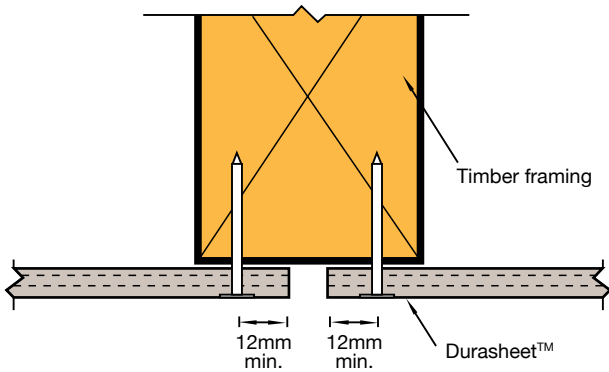

**FIGURE 4 //**  
BUTT JOINT

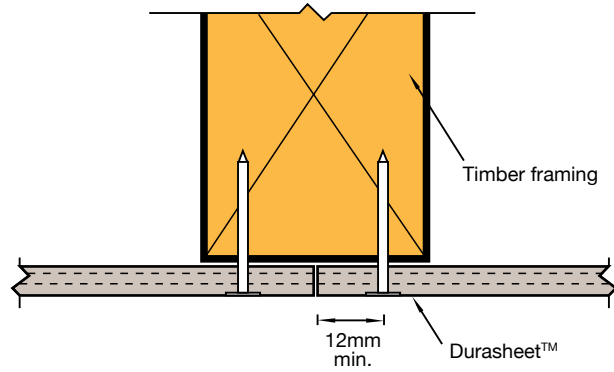

## GARAGE / CARPORT / ALFRESCO LININGS - MAXIMUM BEARER AND FASTENER SPACINGS

### 4.5MM DURASHEET™

WIND CLASSIFICATION		WITHIN 1200MM OF THE EXTERNAL BUILDING CORNERS		ELSEWHERE IN BUILDING	
TO AS 4055	TO QLD STANDARD	MAX. BATTEN SPACING	MAX. FASTENER SPACING	MAX. BATTEN SPACING	MAX. FASTENER SPACING
N1	W28N	450	300	450	300
N2	W33N	350	300	450	300
N3/C1	W41N and C	300	300	400	300
N4/C2	W50N and C	250	250	350	300



## EXTERIOR CLADDING

### FRAMING

- // Framing must be constructed to comply with the Building Code of Australia.
- // The framing must be set to a true plane to ensure a straight finish to the wall.
- // Studs must be spaced at a maximum of:450mm centres for 4.5mm Durasheet™. 600mm centres for 6mm Durasheet™.
- // Noggings must be spaced at a maximum of 1200mm centres. For horizontal sheet fixing noggings must support the sheet joints.
- // Durasheet™ cladding must not be joined off the framing.

### TIMBER FRAMING

Timber framing must comply with AS 1684.2 & .3 -1999 National Timber Framing Code.

Durasheet™ must not be fixed to wet framing. It is strongly recommended that kiln dried timber is used for framing.

If sheets are fixed to 'wet' framing problems may occur at a later date due to excessive timber shrinkage.

### METAL FRAMING

Metal framing must comply with AS 3623 - 1993 Domestic Metal Framing.

Durasheet™ may be fixed directly to lightweight metal framing. The metal framing must not exceed 1.6mm in thickness.

If Durasheet™ is used with rigid steel framing, it must be battened out with either timber or lightweight steel battens prior to fixing.

Timber battens must have a minimum thickness of 40mm to allow adequate nail penetration. Battens supporting sheet joints must have a minimum face width of 45mm.

### SHEET LAYOUT FOR CLADDING

Information in this publication is satisfactory for low-rise (up to two story) domestic and light commercial buildings in non-cyclonic regions.

6mm Durasheet™ cladding may be fixed vertically or horizontally. However most exterior cladding is installed vertically. If horizontal joints are used then adequate flashing must be fitted to prevent ingress of water, see Figure 5.

FIGURE 5 //  
HORIZONTAL JOINT DETAIL

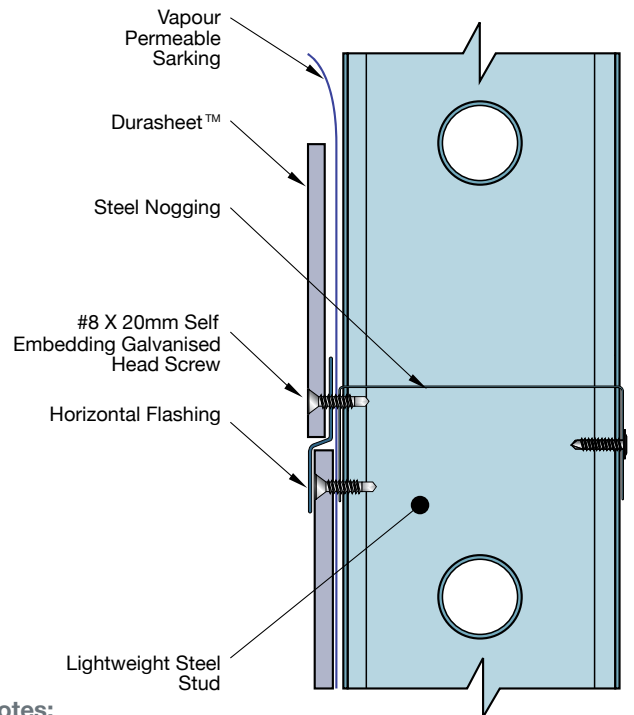

#### Notes:

- // Framing must support all sheet joints.
- // When sheets are fixed more than one sheet high, vertical joints should be staggered by at least one stud (600mm typical).
- // Durasheet™ is to be fixed along all sheet edges over studs at 200mm maximum fixings centres.
- // Do not place fixings closer than 12mm from sheet edges, or closer than 50mm from sheet corners.

### WALL ABUTMENT

Control Joints must be employed when an addition is constructed onto an existing building or when a masonry wall adjoins a timber or steel framed construction.

Control Joints should be constructed using 9mm diameter backing rod and polyurethane sealant on abutment to existing masonry walls.

FIGURE 6 //

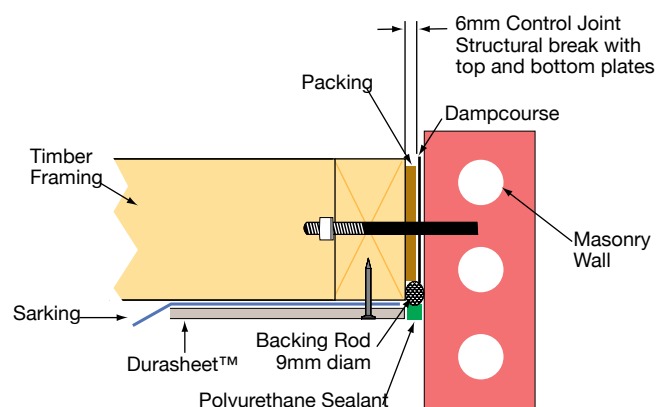

**FIGURE 7 //**  
SHEET JOINT LIGHT WEIGHT STEEL FRAMING

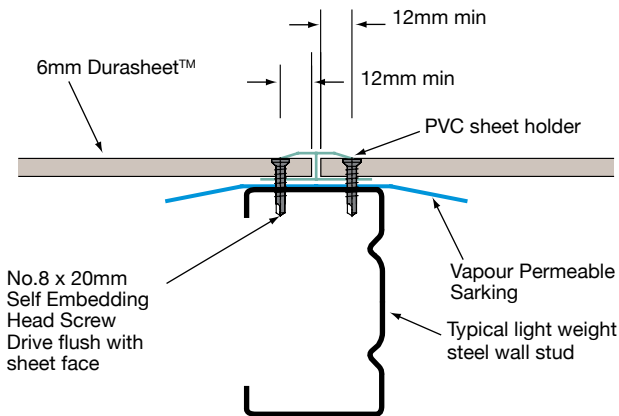

**FIGURE 9 //**  
EXTERNAL CORNERS PVC SHEET JOINERS

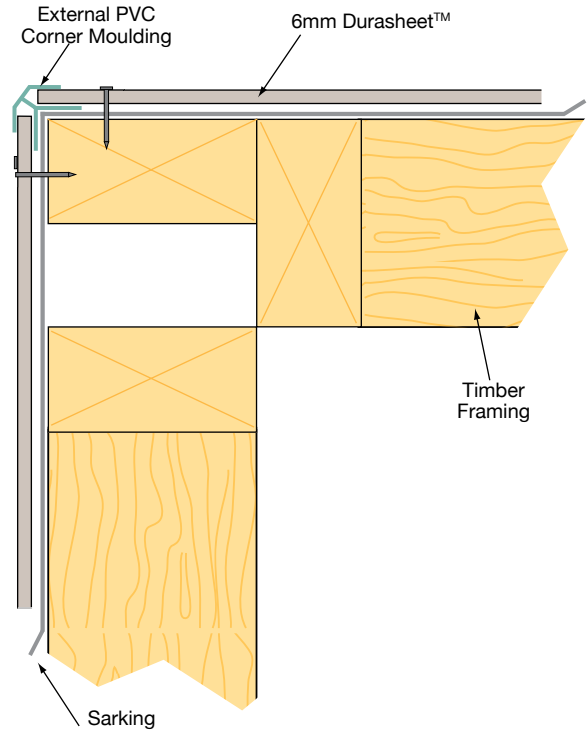

**FIGURE 8 //**  
INTERNAL CORNERS PVC SHEET JOINERY

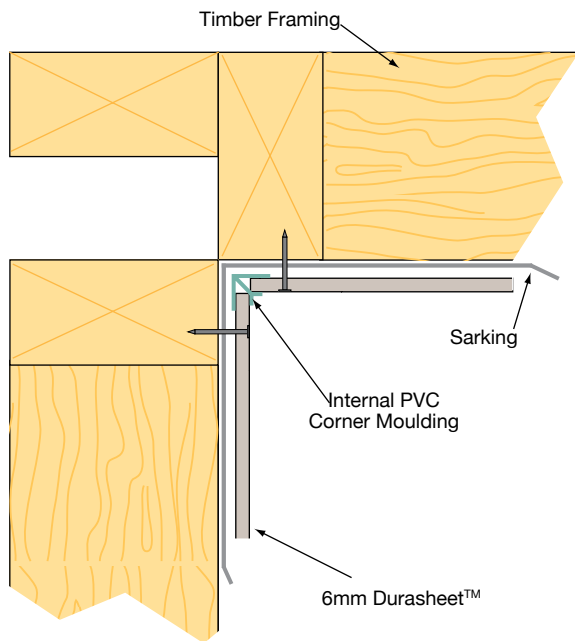

**GROUND CLEARANCE**

Durasheet™ must not be used in situations where it will be below ground or where it will be buried in the ground.

A minimum of 100mm must be maintained from the bottom edge of the sheet to the ground, see Figure 10.

**FIGURE 10 //**  
GROUND CLEARANCE

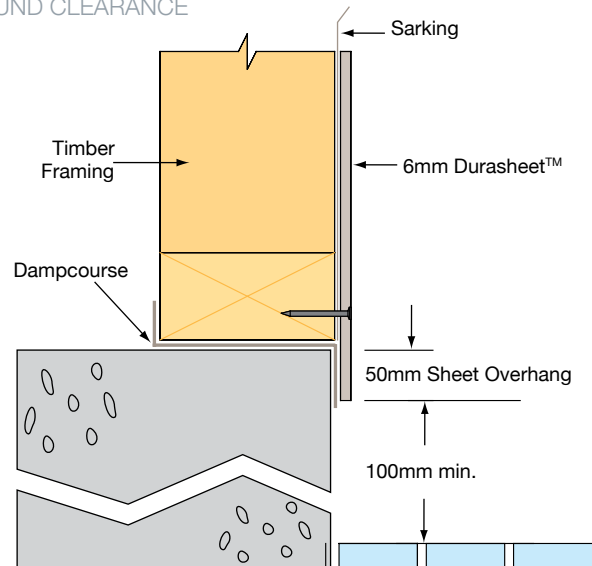
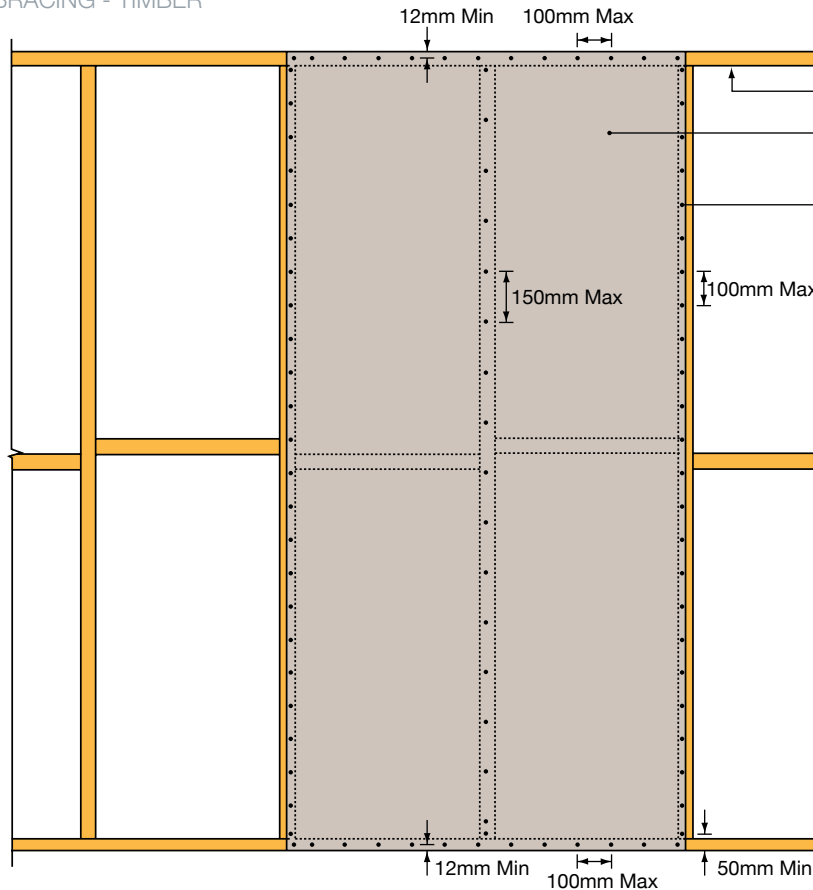

FIGURE 11 //  
TYPE A BRACING - TIMBER



Framing to relevant standard

Fibre Cement cladding fixed to one face only

Fixing as noted

- Use Min 6mm thick Durasheet™.
- Fix cladding with  $\varnothing 2.8 \times 40$ mm (Or equivalent) nails as shown.
- Brace capacity=2.0kN/m.
- Minimum brace length=900mm.
- Fix bottom plate to floor frame below as follows:
  - 2N° 75x $\varnothing 3.15$  Nails to joists below at 600 max centres for plates up to 38mm thick.
  - 2N° 90x $\varnothing 3.15$  Nails to joists below at 600 max centres for plates up to 38mm thick.
- Fix bottom plate to concrete slab below as follows:
  - 1N° 75mm Masonry Nail (Hand driven at slab edge), screw or bolt at 1200 max centres.
- Alternatively, fix wall frame as per AS1684.
- 2700mm max wall height. Capacity of walls greater than 2700mm decreases proportionally with height increase.

FIGURE 12 //  
TYPE A BRACING - STEEL

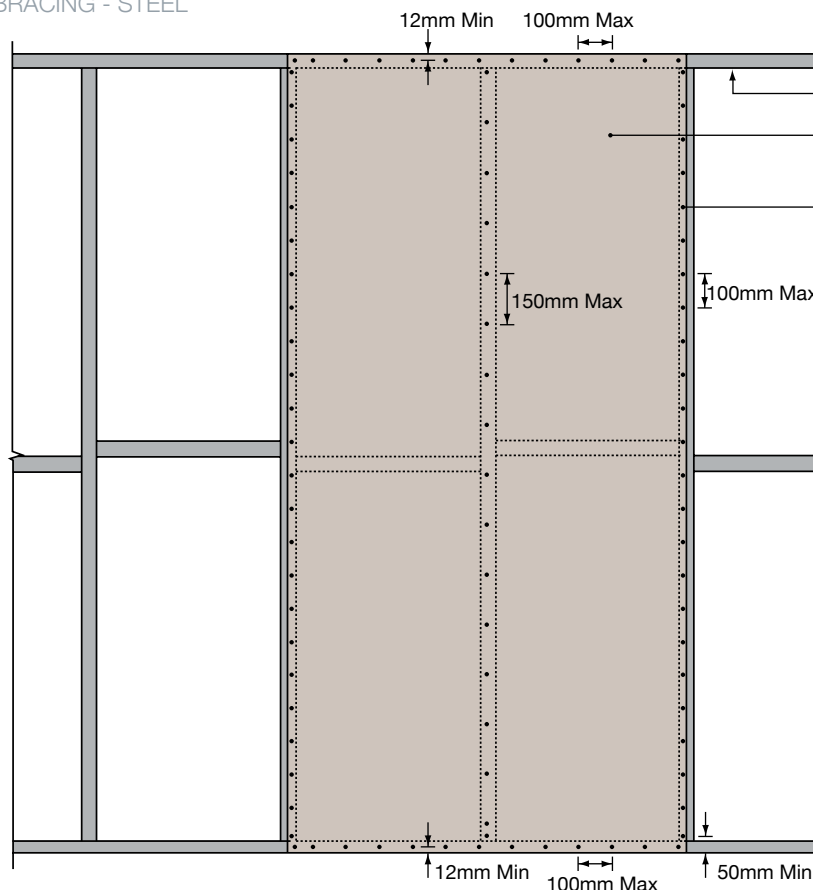

Framing to relevant standard

Fibre Cement cladding fixed to one face only

Fixing as noted

- Use Min 6mm thick Durasheet™.
- Fix cladding with N° 9 Fibre Tek's (or equivalent) as shown.
- Brace capacity=2.0kN/m.
- Minimum brace length=900mm.
- Fix bottom plate to floor frame below as follows:
  - 1N° M10 Bolt at each end and intermediately at 1200 max centres.
- Fix bottom plate to concrete slab below as follows:
  - 1N° M10 Medium Duty Anchor at each end and intermediately at 1200 max centres. Washer may be required to suit stud framing.
- Alternatively, fix wall frame as per nash standard.
- 2700mm max wall height. Capacity of walls greater than 2700mm decreases proportionally with height increase.



FIGURE 13 //  
TYPE B BRACING - TIMBER

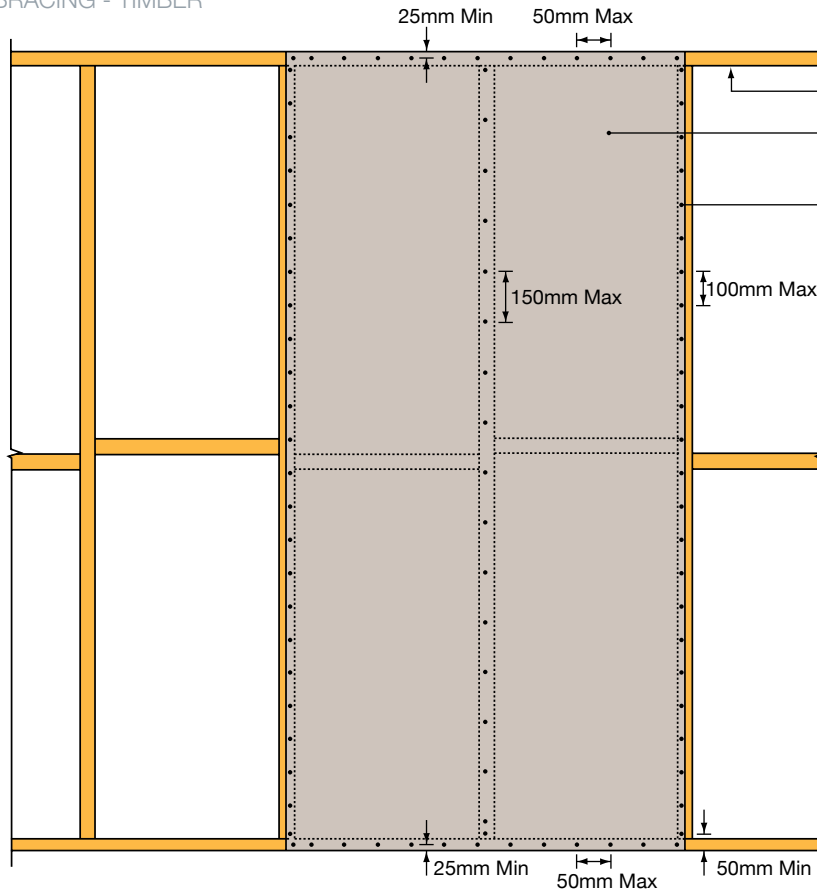

Framing to relevant standard

Fibre Cement cladding fixed to one face only

Fixing as noted

- Use Min 6mm thick Durasheet™.
- Fix cladding with  $\phi 2.8 \times 40\text{mm}$  (Or equivalent) nails as shown.
- Brace capacity=4.0kN/m.
- Minimum brace length=900mm.
- Fix bottom plate to floor frame below as follows:
  - 1N° M10 Bolt at each end and intermediately at 1200 max centres.
- Fix bottom plate to concrete slab below as follows:
  - 1N° M10 Medium Duty Anchor at each end and intermediately at 1200 max centres.
- Alternatively, fix wall frame as per AS1684.
- 2700mm max wall height. Capacity of walls greater than 2700mm decreases proportionally with height increase.

FIGURE 14 //  
TYPE B BRACING - STEEL

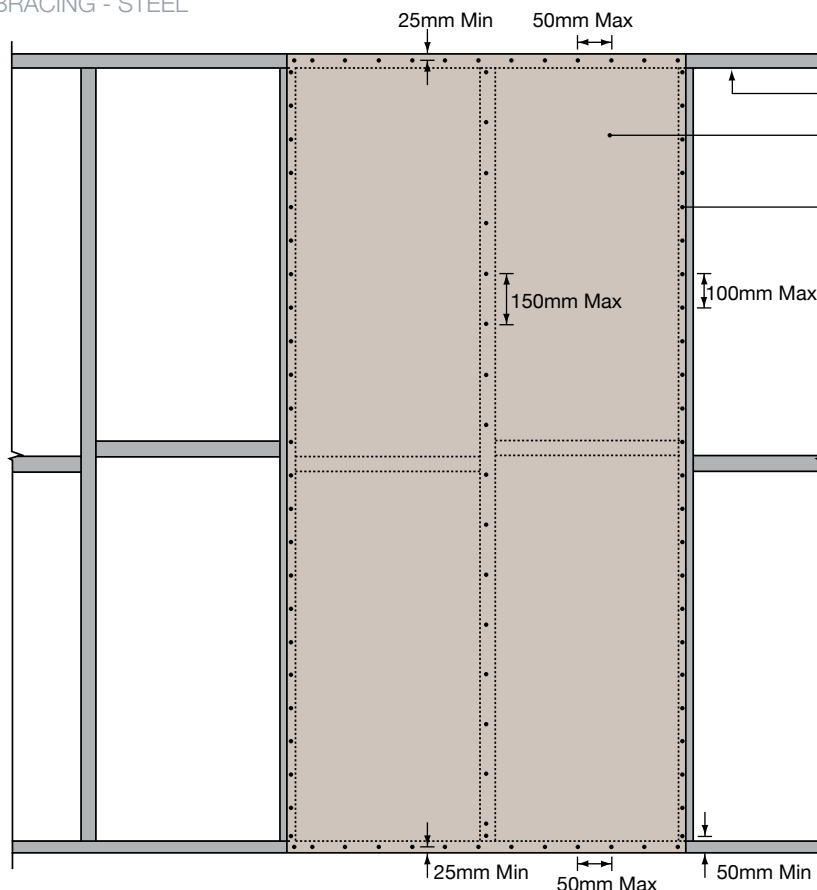

Framing to relevant standard

Fibre Cement cladding fixed to one face only

Fixing as noted

- Use Min 6mm thick Durasheet™.
- Fix cladding with N° 9 Fibre Tek's (or equivalent) as shown.
- Brace capacity=4.0kN/m.
- Minimum brace length=900mm.
- Fix bottom plate to floor frame below as follows:
  - 1N° M10 Bolt at each end and intermediately at 1200 max centres.
- Fix bottom plate to concrete slab below as follows:
  - 1N° M10 Medium Duty Anchor at each end and intermediately at 1200 max centres.
 Washer may be required to suit stud framing.
- Alternatively, fix wall frame as per nash standard.
- 2700mm max wall height. Capacity of walls greater than 2700mm decreases proportionally with height increase.

## DEEMED TO COMPLY

The tabulated data is applicable to Region C (Tropical Cyclone areas) including Darwin and 6mm Durasheet™ is approved for inclusion in the Darwin Deemed to Comply manual.

- // 6mm Durasheet™ Wall Cladding - M/222/1  
14th November 1997
- // 6mm Durasheet™ Soffit Cladding - M/222/2  
14th November 1997

## FIXING & FRAMING 6MM DURASHEET™

Framing Centres (mm max.)	300						
	400						
	450						
	600						
Wind Classification AS 4055-1992	Non Cyclonic	N1	N2	N3	N4	N5	N6
	Cyclonic			C1	C24	C3	C4
Fixing Centres (mm max.)	200						
	150						

## FRAMING AND FIXING CENTRE WIND LOADING - AS 4055 - 1992

FIGURE 15 //

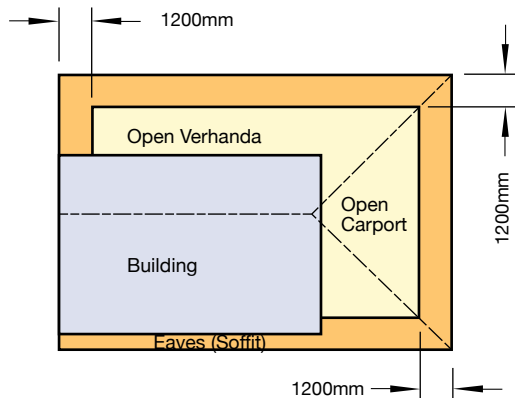

Plan View, Eaves & Soffits Linings Framing & Fixing Requirements

- Normal Areas
- Areas requiring Additional Framing & Fasteners

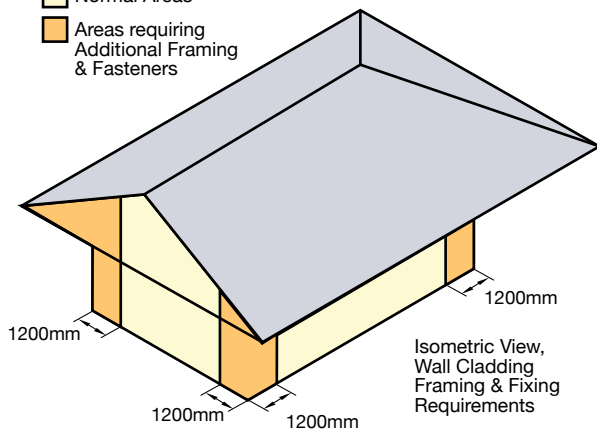

Isometric View, Wall Cladding Framing & Fixing Requirements

## FREEZE THAW

Durasheet™ cladding subject to freeze/thaw conditions must be painted.

Durasheet™ should not be used in situations where it will be in direct contact with snow or ice for prolonged periods.

## BUSHFIRE AS3959:2009 APPLICATIONS

AS3959:2009 sets out a series of Bushfire threat levels to buildings described as BAL (Bushfire Attack Levels) as follows: BAL-12.5, BAL-29, BAL-40 or BAL-FZ (Flamezone).

## BUSHFIRE WALL & EAVES

Durasheet™ is eminently suited for bushfire wall and eaves applications in residential and multi residential buildings. Durasheet™ 6mm can be used as a stand alone product to achieve up to BAL 29 on walls when fixed directly to the frame as per the fixings instructions in this manual.

Durasheet™ 4.5mm can be used as a stand alone product to achieve up to BAL 29 in eaves when fixed directly to the frame as per the the fixings instructions in this manual.

Durasheet™ 6mm can be used as a stand alone product to achieve up to BAL 40 in eaves when fixed directly to the frame as per the the fixings instructions in this manual.

Note: All exterior walls must have Permeable Sarking beneath the Durasheet™. No adhesives are used when installing Durasheet™. Nails or screws must be used.

APPLICATIONS	PRODUCT	BAL
EXTERNAL WALLS	DURASHEET™ 6mm	29
EAVES LINING	DURASHEET™ 4.5mm	29
EAVES LINING	DURASHEET™ 6mm	40

## PAINTING

To enhance both the appearance and performance of Durasheet™, BGC recommend that at least two coats of a water-based paint be applied. The paint manufacturer's recommendation on application and maintenance should be followed.

## MAINTENANCE

Durasheet™ when used in accordance with this literature requires no direct maintenance.

To guard against water penetrating the structure and damaging the framework, annual inspections of the cladding system should be carried out. Check flashing, sealant, joints and paint work.

Flashing and sealants must continue to perform their design function. Damaged sheets should be replaced as originally installed.

## WARRANTY

We warrant that our products are free from defects caused by faulty manufacture or materials for a period of 15 years from the date of purchase. If you acquire any defective products, we will repair or replace them, supply equivalent replacement products or refund the purchase price within 30 days of receiving a valid claim subject to product inspection and confirmation of the existence of a defect by BGC. We will bear the cost of any such repair, replacement or refund.

This warranty is given by:

BGC Fibre Cement Pty Ltd  
121 Bannister Rd Canningvale WA 6155  
Phone 08 9334 4900 Fax 08 9334 4749

To claim under this warranty, you must provide proof of purchase as a consumer and make a written claim (including any costs of claiming) to us at the address specified above within 30 days after the defect was reasonably apparent, or if the defect was reasonably apparent prior to installation, the claim must be made prior to installation. You may not claim under this warranty for loss or damage caused by:

- faulty or incorrect installation by non-BGC installers (BGC's installation procedures are at [bgcinnovadesign.com.au](http://bgcinnovadesign.com.au));
- failure to comply with the Building Code of Australia or any applicable legislation, regulations approvals and standards;
- products not made or supplied by BGC;
- abnormal use of the product; or
- normal wear and tear.

The benefits available under this warranty are in addition to other rights and remedies of the consumer under the law. Our goods come with guarantees that cannot be excluded under the Australian Consumer Law. You are entitled to a replacement or refund for a major failure and for compensation for any other reasonably foreseeable loss or damage. You are also entitled to have the goods repaired or replaced if the goods fail to be of acceptable quality and the failure does not amount to a major failure.



A series of horizontal dashed lines for taking notes.

TO CONTACT  
YOUR NEAREST  
BGC STOCKIST,  
PLEASE CALL:

#### ADELAIDE

71 FROST ROAD  
SALISBURY SOUTH  
SOUTH AUSTRALIA 5106  
TELEPHONE 08 8250 4962  
FACSIMILE 08 8258 2612

#### BRISBANE

53 ARGON STREET  
CAROLE PARK  
QUEENSLAND 4300  
TELEPHONE 07 3271 1711  
FACSIMILE 07 3271 1733

#### MELBOURNE

200 MAIDSTONE STREET  
ALTONA  
VICTORIA 3018  
TELEPHONE 03 9392 9444  
FACSIMILE 03 9392 9404

#### PERTH

121 BANNISTER ROAD  
CANNING VALE  
WESTERN AUSTRALIA 6155  
TELEPHONE 08 9334 4900  
FACSIMILE 08 9334 4749

#### SYDNEY

233 MILPERRA ROAD  
BANKSTOWN  
NEW SOUTH WALES 2200  
TELEPHONE 02 9771 9660  
FACSIMILE 02 9771 9870

#### TECHNICAL HELP LINE

1300 652 242

[BGCINNOVADESIGN.COM.AU](http://BGCINNOVADESIGN.COM.AU)

BGC FIBRE CEMENT IS A PROUD AUSTRALIAN OWNED  
MANUFACTURER OF FIBRE CEMENT PRODUCTS.

BGC FIBRE CEMENT PROVIDES BUILDERS, DEVELOPERS  
AND ARCHITECTS WITH A RANGE OF DESIGN ALTERNATIVES  
AND INNOVATIVE PRODUCTS, SUCH AS:

#### EXTERIOR PRODUCTS AND APPLICATIONS INNOVA RANGE OF PRODUCTS

**DURACOM™** / A compressed fibre cement  
facade system.

**DURAFLOOR™** / Is the ultimate flooring product  
that can be used in both interior and exterior  
applications.

**DURAGRID™ RESIDENTIAL & DURAGRID™  
LIGHT COMMERCIAL** / A light weight facade  
giving a modern and durable finish.

**DURAGROOVE™** / A vertically grooved exterior  
facade panel.

**DURASCAPE™** / A lightweight exterior facade  
base sheet with a subtle vertical shadow line.

**NULINE™ PLUS** / A weatherboard style  
cladding system.

**STONESHEET™** / Purpose designed substrate  
for stone tile facade.

**STRATUM™** / Is a range of plank products, each of  
which can be used as stand alone products or used  
together to create a striking exterior cladding solution.

#### INTERIOR PRODUCTS AND APPLICATIONS BGC FIBRE CEMENT RANGE OF PRODUCTS

**DURALUX™ PLUS** / An interior lining board suitable  
for ceilings and soffits.

**DURALINER™ PLUS** / An interior lining board,  
this is the perfect substrate for tiles and is ideal  
for wet areas.

**CERAMIC TILE UNDERLAY** / A substrate  
for ceramic and slate floor tiles.

**VINYL CORK FLOOR COVERINGS** /  
A substrate for vinyl floors.

#### EXTERIOR PRODUCTS AND APPLICATIONS BGC FIBRE CEMENT RANGE OF PRODUCTS

**DURASHEET™** / Ideal for the cladding of gables  
and lining of eaves. Can also be used on commercial  
soffits and cladding on non impact areas.

**DURAPLANK™** / Available in Smooth, Woodgrain  
and Rusticated finishes, Duraplank™ is ideal for  
exterior cladding of upper storey conversions or  
ground level extensions.

**DURATEX™** / A base sheet used for textured  
coatings on exterior wall applications.

**DURALATTICE™** / Square or diamond patterned  
lattice, suitable for screens, pergolas and fences.

**COMPRESSED** / Used for domestic, commercial  
sheet for wet areas, flooring, partitions, exterior  
decking, fascia and facade cladding.

**DURALUX™ PLUS** / Suitable for exterior applications  
where it will be sheltered from direct weather.



Build it better with BGC

**BGC**

Fibre Cement

**Safe working practices** - Please wear a P1 or P2 mask and safety goggles (approved to AS/NZW1337 standards) whilst cutting  
or installing Durasheet™. Durasheet™ can be safely handled during unloading or stacking without the use of these precautions.

**Cleaning up** - Always wet down your work area when cutting Durasheet™, to ensure that dust is managed.  
Dispose of any vacuumed dust with care and using containment procedures.

Design by **The SHAPE Group** [www.theshapegroup.com.au](http://www.theshapegroup.com.au)